

AMITY's Bi-Directional Meter

R.W.Miller PhD, PE

AMITY has introduced a Bi-Directional Meter following design guidelines presented in the AMITY design paper (Appendix A). The meter was calibrated at the Alden Hydraulic Laboratory; results are presented in Figure 1.

Meter design used the following criteria

- The Venturi entrance and diffuser are identical and follow AMITY's diffuser design; A 7.5° cone with a Gibson exit to the pipe diameter.
- The throat section to be the AMITY design with the overall throat length following the standard ASME Venturi length.

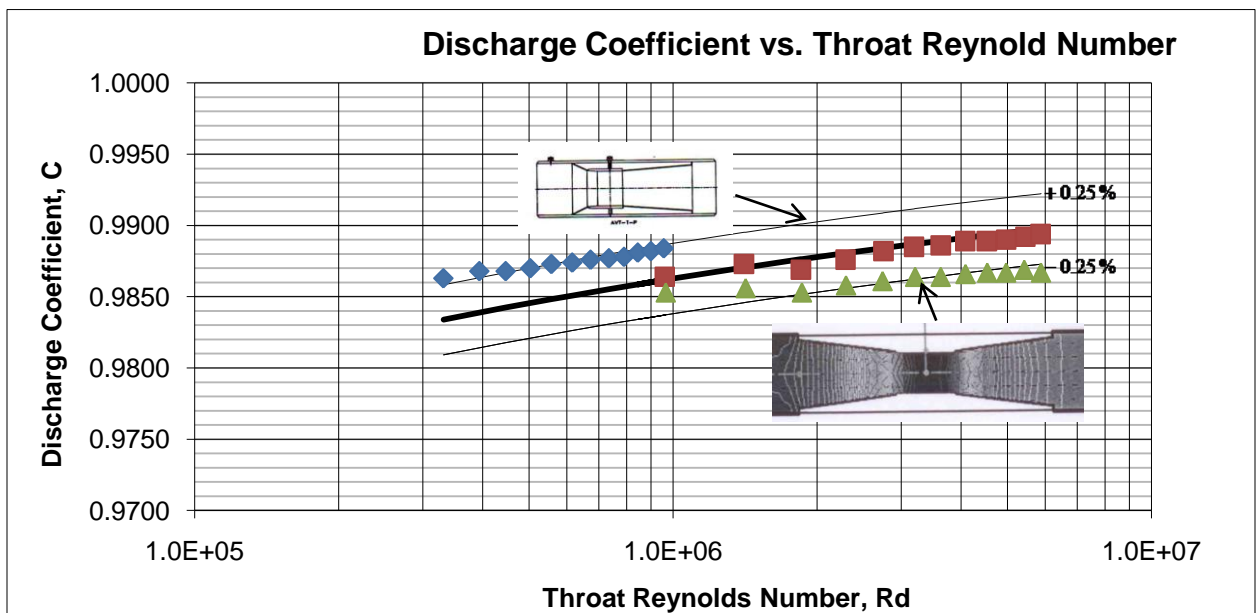

Figure 1 Discharge coefficient for AMITY's Bi Directional flowmeter.

No two inlets can be exactly reproduced; the reason two identical meters cannot yield exactly the same laboratory test result; machining and laboratory bias and precision being the source of error. When evaluating performance a Bi-Directional meter should be viewed as two separate meters.

- A meter with the flow in one direction
- A meter with the flow in the opposite direction.

In Figure 1 it is noted that the Bi-Directional meters 1 and 2 are lower than the standard AMITY meter, which is to be expected because of the increased pressure loss for the inlet geometry. The data, however, is within $\pm 0.25\%$.

Of interest is the Bi-Directional meters have a discharge coefficient approximating the ASME non-machined inlets value of 0.985, most probably caused by slight additional pressure loss created by the forward facing step preceding the inlet convergence.

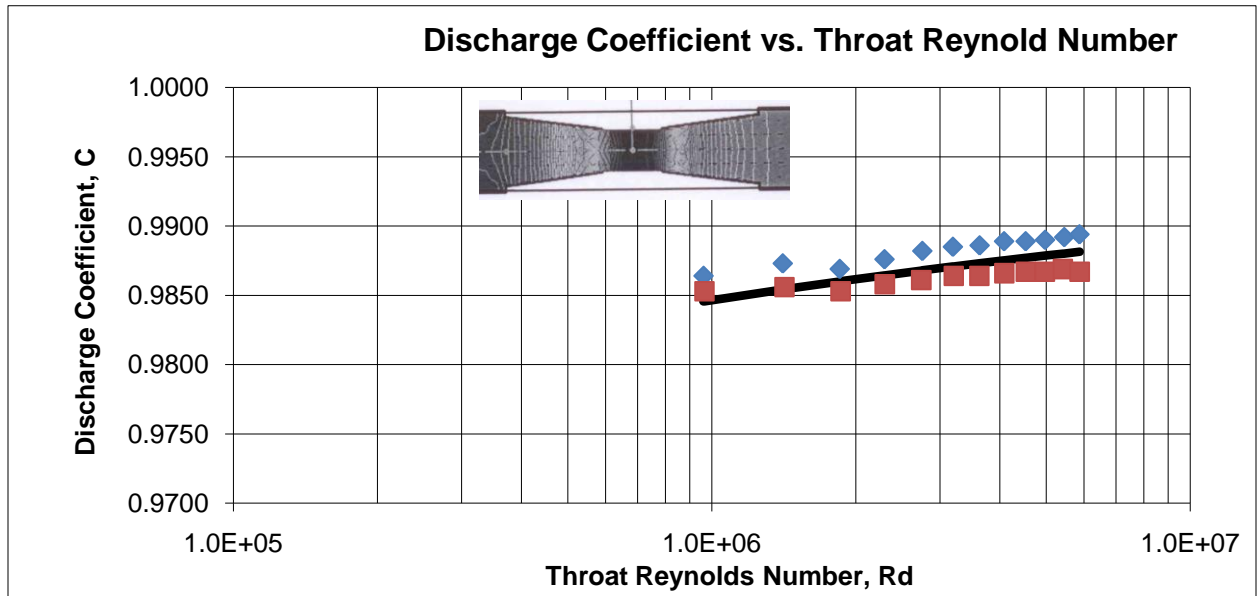

Figure 2 Discharge coefficients for AMITY's Bi Directional flowmeter.

Shown in Figure 2 are the results for the Bi-Directional meter with flow in one direction and then in the other (see Appendix B). The meters displayed an average bias of $\pm 0.103\%$. A single equation can be used to represent the data over the calibration range and for extrapolation purposes.

The combined Bi-Directional discharge coefficient; derived by the Keyser-Murdock (1990) extrapolation method is

$$C = 0.99633 - \frac{0.185}{R_d^{0.2}} \pm 0.125\%$$

References

Gibson, A.H., Hydraulics and Its Applications, Constable & Company, London England 1961
 Keyser, D.R., Murdock, J.W. and Theoretical Basis for Extrapolation of Calibration Data of PTC-6 Throat Tap Nozzles, Jrl Pwr, Paper 90-JPGC-PTC28-4, 1990

Appendix A

AMITY Nozzle-Venturies

R.W.Miller PhD, PE

The AMITY design objective was to have meters perform to the ASME PTC throat tap nozzle design (ASME-PTC-6, 1996). This meter is used for high accuracy performance tests in nuclear power plants. The success of this design is based on established metering principles. The AMITY meters have met these criteria while competitive meters have not produced data to support this performance level.

The AMITY throat metering section replicates the PTC-6 design. Test data confirms that the AMITY “S” and “T” designs have similar PTC-6 published calibration results, leading to the following conclusions,

- The history of calibration tests on PTC-6 nozzles can be applied to the AMITY designs.
- Tests to date are within $\pm 0.15\%$ of expected performance for a single tapping.
- Extrapolation easily meets The PTC-6 requirements (ASME PTC-6A, 2000).
- An un-calibrated accuracy of $\pm 0.50\%$ is supported, with a future potential of $\pm 0.25\%$

DESIGN OBJECTIVES

- Size and Compute dimensions with the The FLOW CONSULTANT (2010) PC software.
- Compute and manufacture critical dimensions based on pressure and temperature corrections presented in Miller *Flow Measurement Engineering Handbook* (GENERIC SOLUTION (pg 9.107-9.117 3rd Edition))
- Minimize overall pressure loss using the Gibson method to design the recovery cone
- Streamline the flow through all sections to minimize overshoot and overall pressure loss
- Easily and timely add user inputs and requirements to module.
- Develop and check AMITY module equations using Math Cad and the CFD AMITY program
- Continually update discharge coefficient equations based on newly obtained laboratory data.

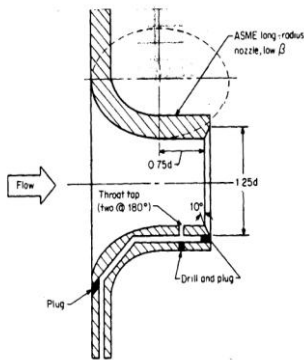

Figure 1 ASME PTC-6 Nozzle profile

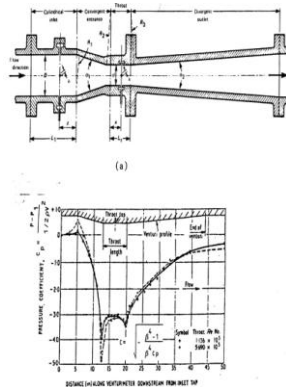

Figure 2 ASME Venturi Pressure Profile

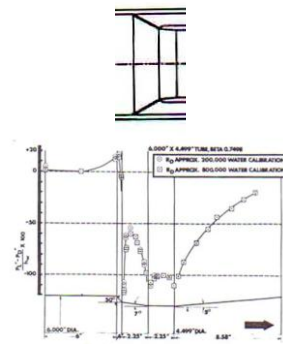

Figure 3 Halmi (1973) Pressure profile

The ASME PTC-6 nozzle is illustrated in Figure 1. The elliptical entrance section pressure profile is essentially a smooth favorable pressure gradient (Rivas, R.A. and Shapiro, 1954) as it enters the throat. The pressure profile and geometry for the ASME Venturi is shown in Fig. 2 and that of the dual entrance cone HALMI (1973) in Fig. 3. Note that the ASME Venturi and HALMI dual cone have a distinct pressure transition into the throat region; this has been eliminated in the AMITY design. In viewing a Nozzle-Venturi three distinct sections are noted

- The favorable pressure gradient entrance to the throat section.
- The cylindrical throat region.
- The adverse pressure gradient recovery cone region.

Each of these regions was designed using technical papers and a Computational Fluid Dynamic (CFD) program. A CFD analysis being used to determine optimum design criteria for the inlet section, throat (or metering section), and to confirm the Gibson (1961) recovery cone derivation.

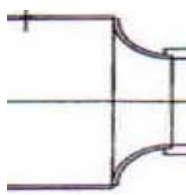

Figure 5 S Design

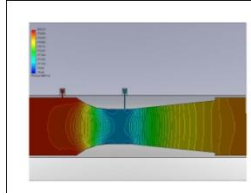

Figure 6 T Design

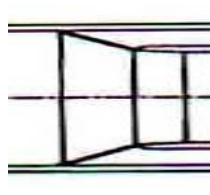
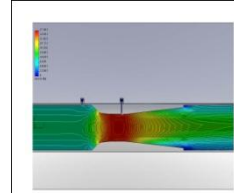

Figure 7 Gibson Recovery Design



Illustrated above are the geometries and resulting CFD's for the two basic AMITY designs.

S-Design A cylindrical radius is the inlet geometry. The entrance to the PTC-6 throat section is critical to insure boundary layer development length is in accordance with the PTC-6 theoretical extrapolation requirement (Keyser and Murdock, 1990). AMITY S-design use an inlet geometry of the Standardized Toroidal Throat Nozzle (ASME/ANSI MFC-7M, 1990), extensive data and CFD studies show excellent entrance to the throat results for this geometry.

T-Design A Halmi double cone entrance with a unique cone angles and a throat entrance developed based on test results in Holland (Miller 1989), with confirming CFD studies.

Recovery cone geometry for both S and T is designed in accordance with the analysis developed by Gibson (1960) and results confirmed using CFD studies.

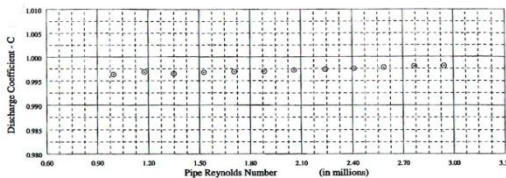

Figure 8 Typical Calibration Data

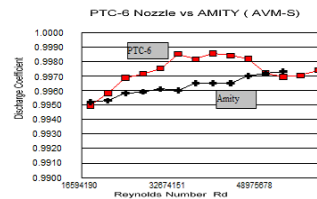

Figure 9 Comparison to PTC-6 data

Calibration Shown in Figure 8 is a typical calibration curve and in Figure 9 a comparison of data to a PTC-6 nozzle calibration.

References

- ASME/ANSI MFC-7M Measurement of Gas Flow by Means of Critical Flow Venturi Nozzle, ASME NY 1987
- ASME PTC-6 Performance Test Code 6 on Steam Turbines, ASME, NY, 1996
- ASME PTC-6A Steam Turbines (Performance Test Code) Appendix Section 5, ASME, 2000
- The FLOW CONSULTANT, PC Software for differential producers and linear flowmeters, R.W.Miller & Associates, Inc. 2010
- Gibson, A.H., Hydraulics and It's Applications, Constable & Company, London England 1961
- Hall, G.W. Application of Boundary Layer Theory to Explain some Nozzle and Venturi Peculiarities Trans. IME, London Vol. 173 No.36 1959
- Halmi, D Metering Performance Investigation and Substantiation of the "Universal Venturi Tube" (U.V.T) ASME Paper 73-WA/FM-3 ASME 1973
- Keyser, D.R., Murdock, J.W. and Theoretical Basis for Extrapolation of Calibration Data of PTC-6 Throat Tap Nozzles, Jrl Pwr, Paper 90-JPGC-PTC28-4, 1990
- Miller, R.W., Test Results on a 36 inch Venturi, R.W.Miller unpublished, 1996
- Miller, R.W. Flow Measurement Engineering Handbook McGraw Hill, 1997
- Rivas, R.A. and Shapiro, A.H On the Theory of Discharge Coefficients for Rounded-Entrance Flowmeters and Venturis, ASME Paper 54-A-98, 1954

APPENDIX B

AMITY FLOW

Purchase Order Number: 1004-01
 16" BI-DIRECTIONAL METER
 Serial Number: TEST FLOW #2

CALIBRATION
 DATE: April 9, 2010
 PIPE DIAMETER = 15.2500
 THROAT DIAMETER = 7.6200

Run #	Line Temp Deg F	Air Temp Deg F	Net Weight lb.	Run Duration secs.	Output [sec note]	Flow GPM	H Line FT H2O	Pipe Rey. # x 10 ⁶	Coef
1	99	74	96071	70.462	8.874~	9880.	72.263	2.9384	0.9867
2	99	74	95980	76.296	7.850~	9116.	61.503	2.7111	0.9869
3	99	74	95832	83.033	6.924~	8363.	51.778	2.4845	0.9867
4	99	74	95531	90.746	6.096~	7628.	43.080	2.2687	0.9867
5	99	74	95463	100.781	5.316~	6864.	34.889	2.0436	0.9866
6	99	74	95376	113.453	4.612~	6092.	27.493	1.8137	0.9864
7	99	73	95346	128.267	4.041~	5386.	21.494	1.6037	0.9864
8	99	74	95132	149.516	7.998~	4610.	15.759	1.3712	0.9861
9	99	74	95142	178.309	6.220~	3866.	11.089	1.1499	0.9858
10	99	73	78361	181.374	4.768~	3130.	7.276	0.9301	0.9853
11	99	73	59336	180.052	3.609~	2388.	4.232	0.7094	0.9856
12	99	73	41036	182.862	2.745~	1626.	1.963	0.4831	0.9853

AMITY FLOW

Purchase Order Number: 1004-01
 16" BI-DIRECTIONAL METER
 Serial Number: TEST FLOW #1

CALIBRATION
 DATE: April 9, 2010
 PIPE DIAMETER = 15.2500
 THROAT DIAMETER = 7.6200

Run #	Line Temp Deg F	Air Temp Deg F	Net Weight lb.	Run Duration secs.	Output [sec note]	Flow GPM	H Line FT H2O	Pipe Rey. # x 10 ⁶	Coef
1	98	72	96038	75.003	8.032~	9277.	63.399	2.7265	0.9892
2	98	72	96313	69.835	8.995~	9991.	73.513	2.9334	0.9894
3	98	72	95827	82.090	7.013~	8457.	52.703	2.4856	0.9890
4	98	72	95557	89.863	6.160~	7704.	43.744	2.2642	0.9889
5	98	72	95569	99.817	5.372~	6936.	35.470	2.0409	0.9889
6	98	72	95504	112.326	4.660~	6160.	27.988	1.8144	0.9886
7	98	73	95358	127.551	4.056~	5416.	21.642	1.5954	0.9885
8	98	73	95249	147.755	8.130~	4670.	16.102	1.3772	0.9882
9	98	73	95102	177.184	6.254~	3889.	11.176	1.1479	0.9876
10	98	73	77857	179.938	4.768~	3135.	7.273	0.9254	0.9869
11	98	73	59737	181.564	3.598~	2383.	4.202	0.7036	0.9873
12	98	73	40489	180.161	2.746~	1628.	1.964	0.4806	0.9864